

# LINEAR TABLE POWER OUTLET

— Thomas Bentzen

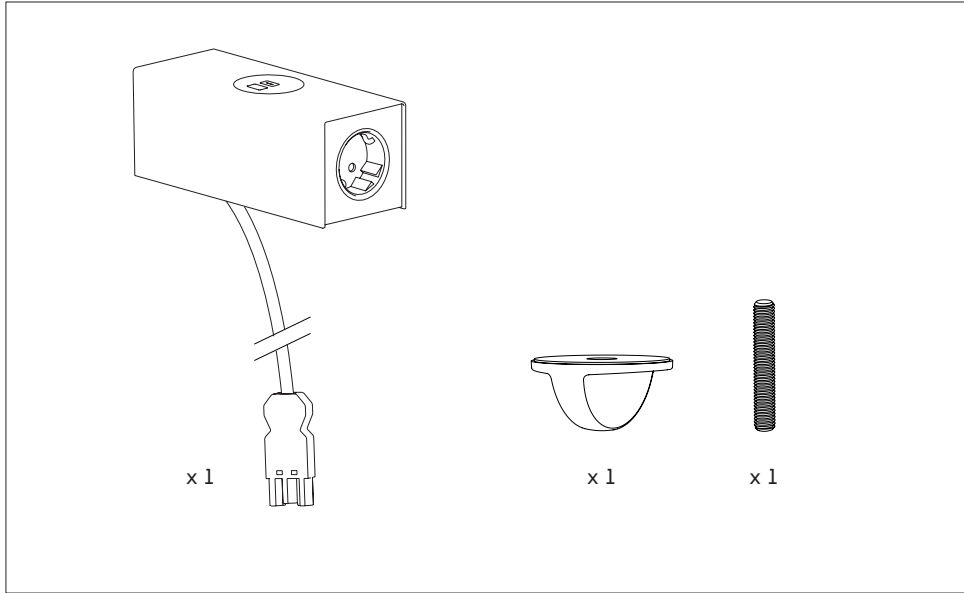

1

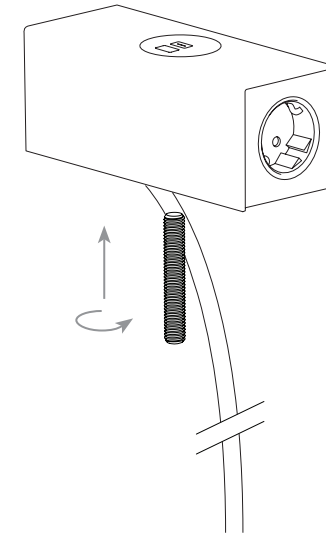

ASSEMBLY INSTRUCTION – SAMLE MANUAL – MONTAGEANLEITUNG  
INSTRUCTIONS DE MONTAGE – INSTRUCCIONES DE MONTAJA

2

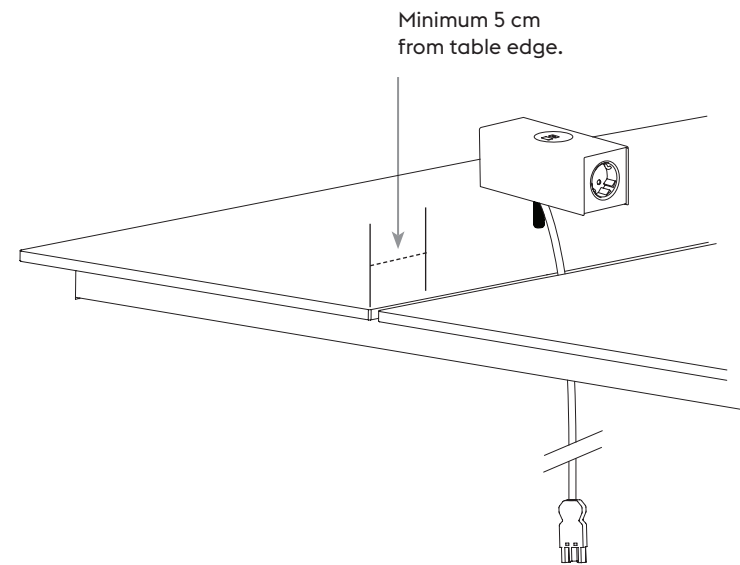

RATED VOLTAGE: 250 V  
RATED CURRENT: 16 A  
RATED IMPULSE VOLTAGE: 4 KV  
INGRESS PROTECTION: IP20  
CABLE TYPE: HO5VV-F  
FIRE CLASS: ECA  
OBSERVE LOCAL REQUIREMENTS FOR CONNECTION OF MULTIPLE UNITS

USB charging with 3-4 available supply voltage depending on the devices being charged.  
Intelligent Device Recognition ensures that the device is charged at the optimal level  
in the shortest time. Rated total output power (combined) = 25W

Charging current:  
USB-A outlet max 18W (5V / 3A, 9V / 2A or 12V / 1.5A)  
USB-C outlet max 24W (5V / 3A, 9V / 2.22A, 15V / 1.65A or 20V / 1.2A)  
Standby power = 0.05W

Blue LED indication for USB-C when in standard fast charging mode (up to 5V)  
Green LED indication for USB-C when in Power Delivery charging mode for devices  
that accepts 9-20V providing the most optimal charge.



3

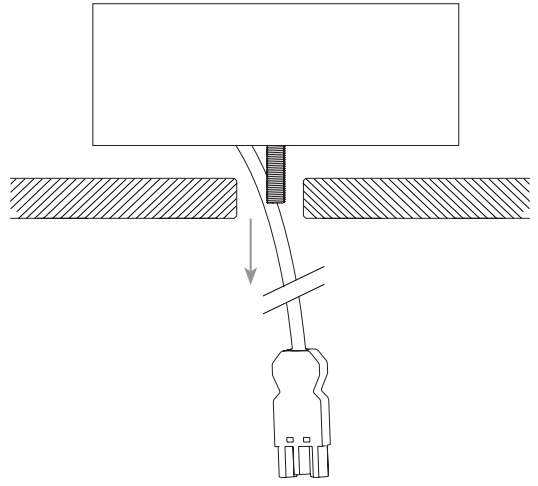

5

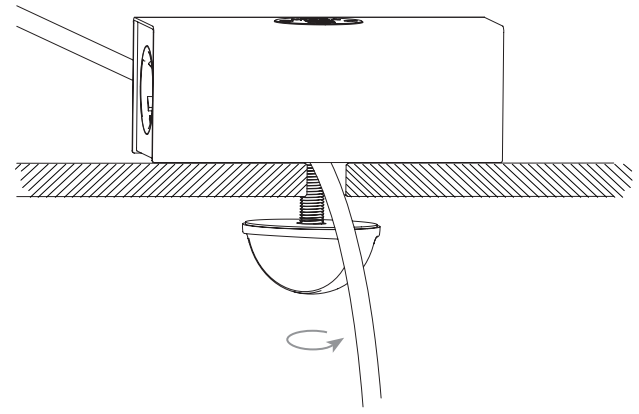

4

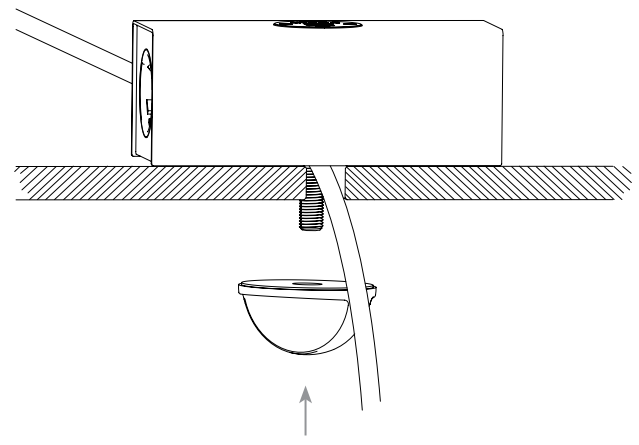

6

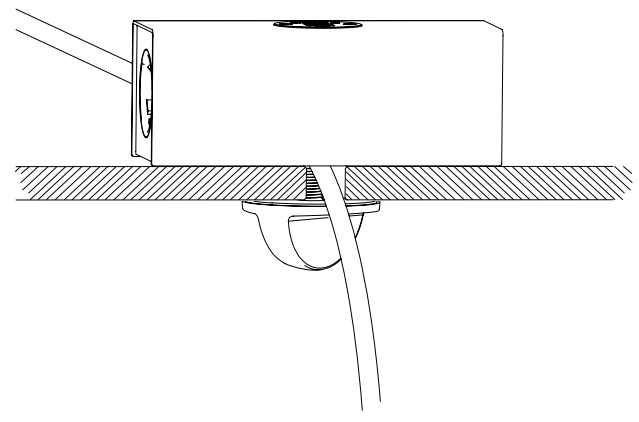

7

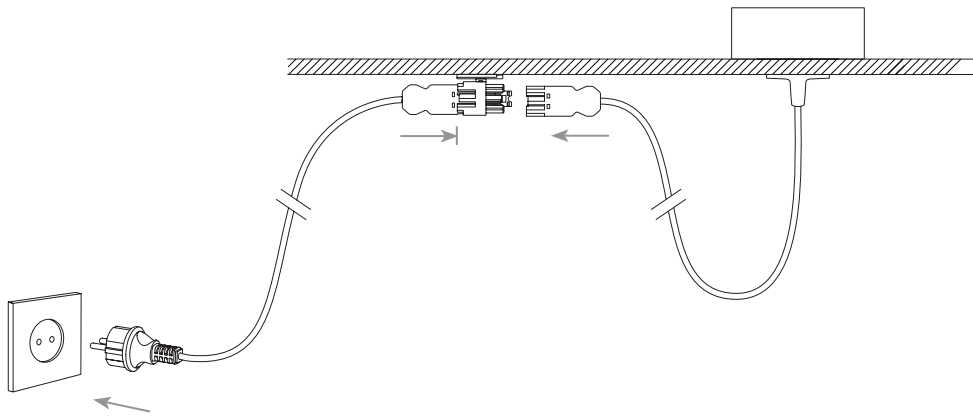

8

- EN To release the Wieland GST1813 plug from the distribution block, lift the latch indicated on the illustration by using a flat screwdriver or similar tool and firmly pull out the plug.
- DK For at tage Wieland GST1813-stikket ud af fordelerblokken skal man løfte låget som indikeret på illustrationen ved at bruge en flad skruetrækker eller lignende værktøj hvorefter stikket trækkes ud.
- DE Lösen Sie den Wieland GST1813-Steckverbinder aus dem Verteilerblock, indem Sie die in der Abbildung gezeigte Arretierung mit einem Flachschaubenzieher oder einem ähnlichen Werkzeug anheben und kräftig am Steckverbinder ziehen.
- FR Pour libérer la fiche Wieland GST1813 du répartiteur il faut soulever le loquet représenté sur la figure à l'aide d'un tournevis plat ou d'un outil équivalent et tirer fermement sur la fiche.
- ES Para sacar el conector Wieland GST1813 del bloque de distribución, levante el enganche indicado en la ilustración con un destornillador plano o una herramienta similar y tire del conector con firmeza.

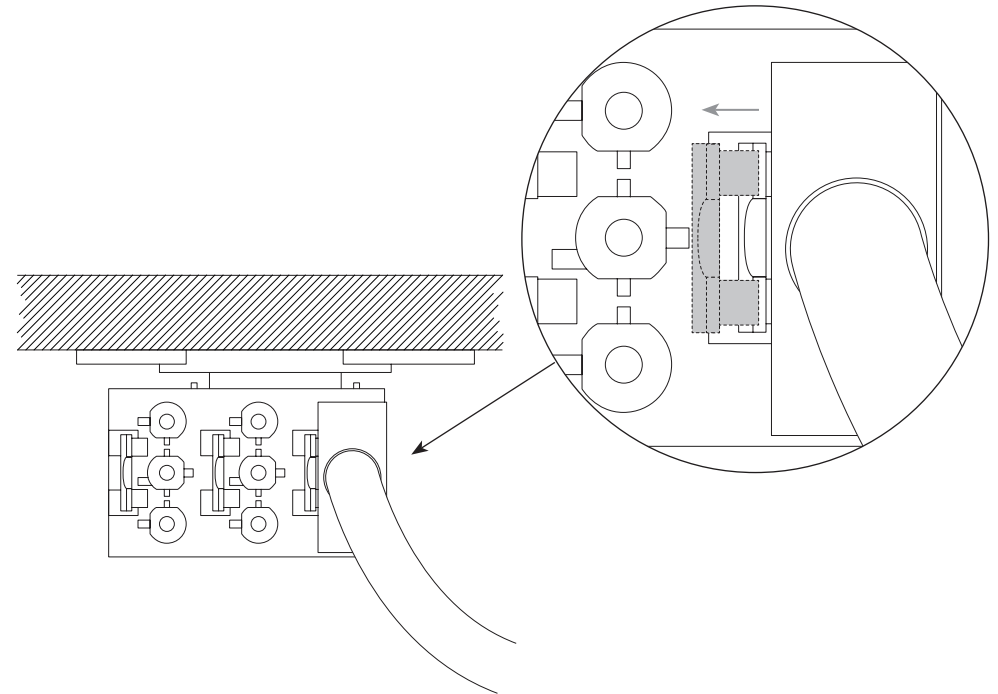

## CLEANING — RENGØRING — REINIGUNG — NETTOYAGE — LIMPIEZA

- EN Turn off electricity, clean with dry cloth.
- DK Afbryd elektricitet, rengør med tør klud.
- DE Strom abschalten, mit einem trockenen Tuch reinigen.
- FR Eteindre l'électricité, nettoyer avec un chiffon humide.
- ES Apague la electricidad, limpie con un paño seco.

## ATTENTION — BEMÆRK — ACHTUNG — ATTENTION — ATENCIÓN

- EN The external flexible cable or cord of this device cannot be replaced; if the cord is damaged, the device shall be destroyed.
- DK Det eksterne fleksible kabel eller ledningen til denne enhed kan ikke udskiftes. Hvis ledningen er beskadiget, skal enheden destrueres.
- DE Das externe Flexkabel bzw. die Schnur zu diesem Gerät kann nicht ausgewechselt werden. Wenn das Kabel beschädigt ist, muss das Gerät entsorgt werden.
- FR Le câble flexible ou le cordon d'alimentation externe de cet appareil ne peut être remplacé ; s'il est endommagé, l'appareil doit être détruit.
- ES El cable o cordón flexible externo de este dispositivo no puede sustituirse; si el cable está dañado, el dispositivo deberá ser destruido.